

I/O PLUS II

Table of Contents

IBM PC™, PC/XT™, PC/AT™ are registered trademarks of
International Business Machines Corp. Page

1.0	Introducing the I/O Plus II	1
1.1	*Do I really Need to Read This Manual?''	2
1.2	System Requirements – Non-PC DOS™ Operation	2
2.0	Getting Started	3
2.1	Removing the PC™ System Unit Cover	3
3.0	Serial Asynchronous Communication Using Serial Port # 1 (and Option S, Serial Port # 2)	4
3.1	Setting Up Serial Port # 1	5
3.2	If Your System Already Has a Serial Port	5
3.3	RS-232 Connector Pin List for Serial Port # 1	6
3.4	Disabling Serial Port # 1	8
3.5	Option S: Serial Port # 2	8
3.6	Verifying Your Serial # 2 Configuration	8
3.7	DTE and DCE Interface Selection for Serial # 2	9
3.8	Setting Up Serial # 2 for DCE Configuration	9
3.9	DCE Donfiguration: Serial # 2 RS-232 Pin Connector Listing	10
3.10	Installing the Serial # 2 Interface Cable.	10
3.11	Configuring Your Application Software	11
3.12	Disabling Serial Port # 2	12
4.0	Parallel Printer Port (Option P)	13
4.1	Installing the Interface Cable	13
4.2	Reconfiguring Your Parallel Port for Multi-Port Systems	14

4.3	Reconfiguring Your Parallel Printer Software	15
4.4	Printer Port Connections	15
4.5	Disabling the Parallel Printer Port	15
5.0	Clock-Calendar Feature	17
5.1	Initialization	17
5.2	Setting the TIME and DATE	18
5.3	Device Addressing of the Clock-Calendar	19
6.0	Game Adapter Port	20
6.1	Mounting the Connectors	20
6.2	Configuration	21
6.3	Reconfiguring Your Software	21
6.4	Device Addressing of the Game Adapter	22
6.5	Disabling the Game Adapter Port	22
7.0	Installing Your I/O Plus II Card	23
7.1	Testing the New Installation	24
8.0	User Upgrade Information	25
Appendices		
Appendix A:	Recommended Serial Port Cabling	26
Appendix B:	Switching Between LPT1 and LPT2	34
Appendix C:	Clock-Calendar Chip	36
Appendix D:	Patches for Specific I/O Problems	38
Appendix E:	Wiring RS-232 Serial Interfaces	41

I/O Plus II Schematic Diagrams

DIAGRAM A:	I/O Plus II Board Layout	
------------	------------------------------------	--

1.0 Introducing the I/O Plus II

The I/O Plus II™ is a versatile and powerful data I/O accessory for your IBM™ Personal Computer (PC)™. The real time clock with battery backup, the RS-232 asynchronous serial communications port, and the game adapter port (all standard), along with the optional second serial port and parallel printer port, make the I/O Plus II the ultimate in expansion hardware.

Research gives you two valuable utility programs. SuperDrive™ a disk emulation program allowing you to use part of your memory as a superfast "electronic diskdrive"; and SuperSpool™, an intelligent print spooler allowing you to output files to a printer without typing up your PC™.

Compatibility

The I/O Plus II is completely compatible with the PC™, PC-XT™, PC™ Expansion Unit, T.1 Professional Computer, and the Compag. However, because the XT™ has a serial port built-in, an I/O Plus II that is being installed in an XT™ can have only one serial port. This port must be configured as COM2 (see section 3.2).

Standard Features

*A battery back-up real time clock so that you don't have to re-enter the time and date every time you start your system. The battery power is only used when your system is turned off.

*An RS-232C serial interface to be used with a MODEM, serial printer, remote display terminal, other serial device, or as an asynchronous communications port to another computer or peripheral operating under separate asynchronous communications software control. (Note a current loop teletype interface is not supported.)

*Game adapter ports which can be used with IBM™-compatible joysticks or Apple II-compatible joysticks.

*I/O Channel Bus Expansion for future enhancements.

Available Options

*A parallel printer port to be used for connecting a parallel printer to the PCTM.

*A second RS-232C serial port (serial #2, configurable as DTE or DGE) to be used with a MODEM, serial printer, remote display terminal, other serial device, or as an asynchronous communications port to another computer or peripheral operating under separate asynchronous communications software control.

These options may be purchased onboard, or installed by the user at a later date. (Upgrade kits are available from your dealer.)

1.1 "Do I Really Need to Read This Manual?"

AST recommends that you thumb through this manual at your leisure, and read up on the Superpak software utilities.

If you have problems, you should certainly go back and read the appropriate chapter for some helpful hints, and to clarify the conditions necessary for your I/O Plus II card to function properly.

NOTE: BE SURE TO FILL OUT YOUR WARRANTY CARD AND MAIL IT IN.

1.2 System Requirements – Non-PC DOSTM Operation

All references to operating system commands in this manual assume operation under PC DOSTM. The I/O Plus II hardware is completely IBMTM-compatible and will function properly under other IBMTM-approved operating system software. Of course, configuring the I/O ports under another operating system requires the use of commands specific to that operating system. See your operating system manual for the appropriate command syntax.

2.0 Getting Started

Before you start disconnecting cables, removing the cover, etc., please take the time to read this manual. Doing so will get you acquainted with the simple procedures you will follow to properly install your I/O Plus II. If you have a working PCTM at hand, you may want to create a new working DOSTM diskette and copy the Super Pak utility files to it. (See the COPY command in your DOSTM manual for instructions.) This will save you some time when you initialize the Clock-Calendar, SuperDrive, and SuperSpool later on. If you wish to wait and copy these command files later on, that's fine too.

2.1 Removing the PC System Unit Cover

It takes only a few minutes to remove the cover from the PCTM, and install the I/O Plus II card into one of the empty slots in your PC'sTM system board or expansion chassis. This manual has all the necessary instructions. Instructions for removing the cover and setting the switches on your system board are also contained in your IBMTM *Personal Computer Guide to Operations*.

CAUTION: Be sure that the power switch is off and the A.C. cord is removed from the system unit. Turn off the printer or any other equipment connected to the computer. Installing any component while the power is on can permanently damage your computer and its components.

1. Looking at the system unit from the rear, notice the two mounting screws at the lower corners of the back panel. Remove the screws, using a flathead screwdriver or a hex wrench.
2. Slide the system unit cover towards the front. When the cover will go no further, carefully tilt it upwards and remove it from the system.

3.0 Serial Asynchronous Communication Using Serial Port #1 (and Option S, Serial Port #2)

Your I/O Plus II can have one or two asynchronous communication ports. Serial # 1 is standard, and serial # 2 is optional. A serial port handles data in a one-bit-after-another fashion, and controls both incoming and outgoing data transmissions.

The serial port is also known as an async (asynchronous) port, or RS-232C interface. Its purpose is to handle non-synchronous serial data transmission between your PCTM and a MODEM, a serial printer, or other serial device. This is a two-way communications link. Data transmissions "across" the link take place in a serial fashion (one bit after another). Multiple wires are installed between either end of the communications link. Your PCTM serial port and the port on the remote serial device use these wires to signal one another. This allows data transmissions in either direction to be controlled properly.

NOTE: An extensive discussion on wiring RS-232 interfaces is presented in Appendix E.)

The IBM PCTM allows up to two serial communication ports, (called COM1 and COM2). Your I/O Plus II serial port # 1 can be set up as either COM1 or COM2. COM1 is the default (factory) setting. PC DOSTM recognizes COM1 and COM2 as serial communication lines. The factory default setting for the optional serial port # 2 is COM2.

To use a communications line, you must make sure the asynchronous communications parameters (baud rate, parity, databits, and stopbits) are properly set. This is done using the MODE command under PC DOSTM or the OPEN command under BASICA. Consult the appropriate manual for details. An I/O Plus II serial port is fully compatible with the parameter ranges specified by the MODE or OPEN command (baud rate, parity, databits and stopbits). Don't be intimidated by these technical terms. You don't need to know the ins and outs of data communication to properly set up your serial

port. All you need to do is use the MODE or OPEN command to match the parameters of your COM line to those of the remote device. Often, the remote device also has settable parameters. Consult your manual or dealer for the best match of parameter settings.

If you change devices, be sure and change your COM line parameter settings accordingly.

3.1 Setting Up Serial Port # 1

Serial port # 1 has a DB25P (plug or male type) connector (J1 in Diagram A) that extends through the mounting bracket of your I/O Plus II card.

If your present system has no serial port, the I/O Plus II serial port # 1 and the optional serial port # 2 are ready for use as shipped. There is no need to alter any of the settings on the I/O Plus II. You may skip ahead to the section entitled "Configuring Your Application Software". If, however, you already have a serial port in your system, you must make several simple changes to the jumpers on your I/O Plus II board.

3 2 If Your System Already Has a Serial Port

This discussion applies only to systems which will have more than one serial port, in which the currently installed port is COM1. If your present system has a serial port (for example, an IBMTM Asynchronous Communication Adapter) you shouldn't have an I/O Plus II with the "S" option as this would bring the total number of serial ports up to three. The operating system only supports two serial ports: your present serial port and the I/O Plus II's standard serial #1.

There are two "Jumpers" that must be moved to change the address of your I/O Plus II's serial port # 1 from COM1 to COM2. (Jumpers are pairs of wire pins that are connected or "jumped" with small, plastic-coated blocks to complete an electrical circuit.)

The process is quick and easy, and can be performed without special tools.

Moving the First Jumper

Place your I/O Plus II card so that the black mounting bracket is towards the right, and find the six jumper pin pairs immediately below the I/O Plus II trademark (see diagram on back page for clarification). Find the first jumper, at the top. Immediately to its right is the designation C1. That stands for COM1. Immediately below C1 are a pair of pins with the designation C2 (for COM2). Move the jumper block from C1 to C2. Once you have done this, you are ready to move the second jumper.

Moving the Second Jumper

Notice the edge connector at the bottom of the card. It is about 3" long and has vertical gold "fingers". Above the edge connector towards its left boundary are the INTERRUPT REQUEST (IRQ) selection jumpers. The jumper positions are labeled to the right of the pins with the designations 5C, 5S, 4, 3, 3S, 2C, and 2S. As shipped, a jumper should be on position 4 (the IRQ line for COM1). To reconfigure your serial port # 1 as COM2, you must move the plastic jumper from position 4 to position 3.

Your I/O Plus II serial port # 1 is now addressable as COM2.

3.3 RS-232 Connector Pin List for Serial Port # 1

In order to attach your PC'sTM serial port to another serial device, you must use a multi-wire cable with the proper type (male or female) connectors at either end. In addition, you must make sure that the proper signals are being exchanged by your PC'sTM serial port and the remote device's serial port. This is simply a matter of matching output lines to input lines and vice versa. For example, the pin which outputs data on the PCTM side of the link should be wired to the pin which receives data on the other side of the link. This is

discussed in more detail in Appendix A and covered extensively in Appendix E.

The table below lists the signal configuration used by the serial port #1 on your I/O Plus I.I. This arrangement is known as DTE (for data terminal equipment). Use this information to make up the proper cable for your particular serial communication environment. Please make sure that pins 5, 6, and 8 (CTS, DSR, and CD) of the DB25P (J1) connector are correctly wired to the proper incoming signals. (See Appendix E.) The PC™ needs to “see” these signals in order to control communications. Note that only some of the 25 pins are used to wire the interface. You don’t need to wire the unused pins. Appendix A has specific examples of correctly cabled interfaces.

If you are using several remote devices, which require different cabling arrangements, consider using adapter plugs to handle the line signal routing. That way you can use the same extension cable for all your devices and simply change the adapter plug when you change device.

Serial Port # 1 as a DTE Interface

RS232C NAME	J1 PIN#	SIGNAL NAME	SIGNAL DIRECTION
AA	1	(Protective Ground)	Common
BA	2	TX (Transmit Data)	OUTPUT
BB	3	RX (Receive Data)	INPUT
CA	4	RTS (Request to Send)	OUTPUT
CB	5	CTS (Clear to Send)	INPUT
CC	6	DSR (Data Set Ready)	INPUT
AB	7	SG (Signal Ground)	Common
CF	8	CD (Carrier Detect)	INPUT
CD	20	DTR (Data Terminal Ready)	OUTPUT
CE	22	RI (Ring Indicate)	INPUT

NOTE: serial ports don't support a current loop type interface.

3.4 Disabling Serial Port # 1

Serial port # 1 on the I/O Plus II card can be completely disabled by removing the jumpers discussed in section 3.2.

3.5 Option S: Serial Port # 2

This section applies only to an I/O Plus II equipped with the "S" option, a second serial port (serial # 2). This is not to be confused with the parallel port option or the previous section on serial # 1. If your I/O Plus II doesn't include this option, it can be added later (see User Upgrade Information).

If you have the S option, your I/O Plus II has two asynchronous serial communications ports. Serial # 1 has already been discussed. As shipped, your serial port # 2 is set up as COM2. If you have the S option, there should definitely be NO serial ports in your PCTM system, other than those on your I/O Plus II card. PC DOSTM (or for that matter any other current PCTM operating system) doesn't support more than two serial ports.

3.6 Verifying Your Serial # 2 Configuration

Your serial # 2 is factory set and ready to use as shipped. You don't need to adjust any jumpers. Just to verify that the jumpers are in their proper positions, let's check the positions of the two jumpers used to control serial # 2.

Verifying the Position of the First Jumper

Place your I/O Plus II so that the black n to the right, and find the set of jumper pins inm I/O Plus II trademark. A jumper block should be bridging the set of pins third from the top, designated as S2.

Verifying the Position of the Second Jumper

Just above the edge connector at the bottom of the card are the interrupt request selection pins (IRQ). A jumper block should be

bridging the two pins designated as 3S.

3.7 DTE and DCE Interface Selection for Serial # 2

Your I/O Plus II has two rows of pin connectors near the top left corner of the card. The top row is used to set up a DTE interface; the bottom row is used for a DCE configuration. These two types of interfaces are discussed extensively in Appendix E. Serial Port # 2 is configured at the factory as a DTE type interface. (This selects the top row of pins, J2.) In this respect, it is identical to serial # 1, which is also a DTE interface. This type of interface is ideal for connecting your serial # 2 to a MODEM, or other DCE type connector.

If you have decided to use the DTE-type interface, you should skip ahead to the section entitled "Installing the Serial # 2 Interface Cable".

The bottom row of pins (J3), DCE type interface, is best used to connect your serial port # 2 to a remote printer, terminal, or other DTE type connector.

3.8 Setting Up Serial # 2 for DCE Configuration

The DCE configuration allows pin-for-pin wiring with a remote DTE type port. This helps save the time and expense of constructing a special cable for connecting like interfaces (see Appendix E). A jumper block selects either the DTE or DCE pin connectors (J2 or J3). The factory configuration is DTE (J2). To use the DCE interface, find the two sets of pins below J3. A jumper block should be bridging the upper pin set, designated as DTE. Remove the jumper and reinstall it so that it bridges the lower pin set, designated as DCE.

You have now selected the DCE type interface, and should install the adapter cable on the lower row of pins, labeled J3 DCE. Installation of the adapter cable is covered in the section entitled "Installing the Serial # 2 Interface Cable".

3.9 DCE Configuration: Serial # 2 RS-232 Pin Connector Listing

Below is the pin out signal arrangement for a serial port # 2 in DCE configuration only. You can use this information if you have to construct a special cable for your DCE type serial interface. For more information on DCE type interface signal arrangement and cabling, see Appendix A and Appendix E.

Serial Port # 2 as a DCE Interface

RS232 NAME	J3 PIN #	SIGNAL NAME	SIGNAL DIRECTION
AA	1	(Protective Ground)	Common
BA	2	TX (Transmit Data)	INPUT
BB	3	RX (Receive Data)	OUTPUT
CA	4	RTS (Request to Send)	INPUT
CB	5	CTS (Clear to Send)	OUTPUT
CC	6	DSR (Data Set Ready)	OUTPUT
AB	7	SG (Signal Ground)	Common
CF	8	CD (Carrier Detect)	OUTPUT
DC	20	DTR (Data Terminal Ready)	INPUT
CE	22	RI (Ring Indicator)	OUTPUT

NOTE: AST serial ports do not support a current loop type interface.

3.10 Installing the Serial # 2 Interface Cable

By now you should know which pin connector (J2, DTE; or J3, DCE) you are going to use. If you don't, go back over the above sections.

Examine the interface cable supplied with your S option. This ribbon-type cable is about eighteen inches long, has a plastic at one end, and a DB25P (plug or male type) connector at the other. The smaller plastic connector plugs into your I/O Plus II board. The larger "D" shaped connector attaches to the cable from your remote serial device.

One edge of the ribbon cable is colored. This is the PIN # 1 side of the cable. Position your I/O Plus II board so that the black mounting bracket is to your right. Now arrange the cable so that the colored edge is towards the left end of the board. The cable should be extending towards the bottom of your I/O Plus II. Position the plastic connector over the row of pins corresponding to the type of interface you have selected, and gently press the connector onto that row of pins. The connector should go on easily with an even, gentle pressure.

Routing the Adapter Cable

The adapter cable may be routed in a variety of ways. If you have an **ConnectAll™** interface extension, you can route the cable there and secure it through one of the available openings. If you have an older **PC™** chassis with a cut-out above the keyboard connection on the back panel, you can knock out the plug in this hole and mount the "D" type connector to the back panel.

Another method is to simply remove the dummy bracket covering an unused expansion slot's back panel window and route the cable out through this opening. If you choose to do this, great care must be taken not to put a strain or any tension on your cable. If all your expansion slots are occupied, you can use the space above serial # 1 to route your serial # 2 adapter cable.

NOTE: It is usually more advisable to route your adapter cable underneath existing boards, rather than over the top. The close tolerances at the top of the **PC™** may produce some wear and tear on your cable, or worse yet, your cover may snag a cable and damage the cable or its pin mounting.

3.11 Configuring Your Application Software

Most communications software can be configured to send data to either serial # 1 or serial # 2 (COM1 or COM2). The default is usually COM1. But what if, for example, your MODEM is connected

to serial # 2 (COM2) and you wish to send data through serial # 2 to a remote location. It may be necessary to reconfigure your application software so that it routes the data to COM2 rather than COM1.

In many cases, the easiest way to accomplish this is to temporarily redirect the activities of COM1 to the COM2 address. This may be done using the MODE command under PC DOSTM. If you wish to redirect output destined for a printer port (for example, LPT1) to a serial port (either COM1 or COM2), the MODE command can do this as well.

NOTE: If you attempt to redirect data to different output ports, be sure that the output port's parameters are properly set to communicate with the device to which it is connected. See your DOS manual for instructions.

If you have any questions about configuring your software, consult the appropriate manual or software dealer.

3.12 Disabling Serial Port # 2

Serial port # 2 on the I/O Plus II card can be completely disabled by removing the jumpers discussed in section 3.6.

4.0 Parallel Printer Port (Option P)

This chapter applies to I/O Plus II boards equipped with the parallel printer (P) option. This is not to be confused with the serial option, discussed in chapter 3. If your I/O Plus II card does not include this option, it can be added later. (See User Upgrade Information.)

The IBM PCTM allows up to three parallel printers to be attached, called LPT1, LPT2, and LPT3. The parallel printer port on the I/O Plus II card is normally addressable as either LPT1 or LPT2. When there is an IBMTM Monochrome Display Adapter card installed in the PCTM, the printer port on the monochrome card is always LPT1, and the I/O Plus II card's parallel port defaults to LPT2. It can be set to LPT3, if desired (see section 4.2). Your I/O Plus II card is configured at the factory as LPT1. If this is the only parallel printer port on your system, your I/O Plus II is ready as shipped. See 4.2 below.

The interface to your parallel port is controlled under PC DOSTM. The MODE command allows you to configure the port's parameters (characters per line, lines per vertical inch). Consult your printer and DOSTM manuals for proper parameter settings.

4.1 Installing the Interface Cable

Place the I/O Plus II card so that the black mounting bracket is towards the right. Near the top of the card, above the AST logo, is the set of pins designated as J4 PRINTER PORT. (See Diagram A at the back of this manual.)

Notice the 18-inch-long gray interface cable supplied with your card. It has a small plastic connector at one end and a DB25S (socket or female type) connector at the other end. The end with the small plastic connector plugs into J4 of your I/O Plus II card. The DB25S connector goes to your printer cable.

One edge of the ribbon-type adapter cable is colored. This marks the wire to be connected to the Pin 1 position of the set of pins labeled J4. Position the connector over J4 of the I/O Plus II card so that the colored edge of the cable is towards the left. The cable should be extending down over the board. Gently press the connector onto the row of pins. It should slide on easily with even pressure.

4.2 Reconfiguring Your Parallel Port for Multi-Port Systems

This section applies only if you are using more than one parallel port.

If you have an IBMTM Monochrome/Printer Adapter card: the printer port on the Monochrome/Printer card is LPT1 and the printer port of the I/O Plus II automatically defaults to LPT2. In this particular case, no reconfiguring is needed on the I/O Plus II card.

If you already have ANOTHER (non-IBMTM Monochrome card) parallel printer port configured as LPT1, you can reconfigure the parallel printer port on the I/O Plus II card to function as LPT2.

Place your I/O Plus II card so that the black mounting bracket is towards the right. Notice the six sets of pins immediately below the I/O Plus II trademark. A jumper block should be on the second pin set from the bottom, designated as P1. That stands for parallel port 1 (LPT1). Immediately above are two pins with the designation P2 (for LPT2). All you have to do is move the jumper from position P1 to position P2. See Diagram A for clarification.

(Note: When the above change is made, and you have an IBMTM Monochrome card, the parallel port on the I/O Plus II card responds as LPT3.)

4.3 Reconfiguring Your Parallel Printer Software

IBM PC DOS™ supports three parallel printer ports. Applications software may select any of these three ports as the output device. The IBM DOS™ 1.1 MODE command presently does not offer the ability to redirect output intended for one parallel port to another. However, a two-line code patch will allow you to internally redirect printer port output between LPT1 and LPT2. See Appendix B for details.

Most PC DOS™ compatible software that sends data to a parallel printer can be configured to send data to whatever parallel port you specify. The default is usually LPT1. If your printer is connected to a parallel port designated as LPT2, it may be necessary to reconfigure your application software to address LPT2. If you have any questions about configuring your software, consult the appropriate software manual or dealer.

4.4 Printer Port Connections

You can use the information below to make a cable for connecting to an IBM™ Parallel Printer or other parallel interface. This is a Centronics-type parallel printer interface. When wiring to other parallel printers, check for variations. Not all printers have the same signal line connections. For minimal interference, you should use twisted pairs for the cable wirings. If you are unsure how to construct a parallel interface cable, ask your printer dealer for assistance.

NOTE: The cable supplied with your I/O Plus II card converts the card's parallel port output into the DB25 line signal format listed in the chart below. The J4 line outputs are supplied for reference only.

Parallel Port Signal Line Configuration

<u>LINE NAME</u>	<u>ADAPTER CABLE</u>		
	<u>J4 Pin</u>	<u>OUTPUT DB25S</u>	<u>IBM MATRIX PRINTER</u>
-STROBE	1	1	1
D0	3	2	2
D1	5	3	3
D2	7	4	4
D3	9	5	5
D4	11	6	6
D5	13	7	7
D6	15	8	8
D7	17	9	9
-ACK	19	10	10
BUSY	21	11	11
PE	23	12	12
SLCT	25	13	13
-AUTOFD	2	14	14
-ERROR	4	15	32
-INIT	6	16	31
-SLCT IN	8	17	36
GROUND	(10, 12, 14, 16, 18, 20, 22, 24)	(18-25)	(16, 19-30, 33)

Note: A dash in front of the line name denotes lines which are functionally active when low.

4.5 Disabling the Parallel Printer Port

The parallel printer port on the I/O Plus II card can be completely disabled by removing the jumper discussed in section 4.2,

5.0 Clock-Calendar Feature

Your standard Clock-Calendar has the following features:

- *24-hour clock
- *Four-year calendar (no leap year)
- *Battery back-up power supply (battery life, approx. one year)
- *User-replaceable Lithium battery
- *Full compatibility with PC DOS™
- *Optional CP/M-86, CCP/M-86, and p-System clock utility software available (See your dealer)

The Clock-Calendar feature answers the TIME and DATE prompts which the DOS™ operating system issues each time you boot the system.

The lithium battery is easily replaceable and should last for about a year. The clock chip on your I/O Plus II is powered by the PC system when your PC is on. The battery is used as back-up power while your PC™ is off. To replace the battery, slightly lift the retaining clip with your finger and use a small screwdriver to remove the battery from its holder. Replacement batteries can be purchased from the factory or your local watch or appliance store. (Part number Panasonic BR2325)

Take care not to damage or bend the retaining clip by lifting it too far. The clip completes an electrical circuit and must make solid contact with the positive (+) side of the battery. When installing a new battery, make sure it is clean and dry.

5.1 Initialization

To initialize the clock-calendar feature (after you have installed

your I/O Plus II card), copy the two clock programs, ASTCLOCK.COM and SETCLOCK.COM to your working DOSTM diskette. These programs are on the SuperPak diskette supplied with your I/O Plus II. Your working DOSTM diskette must contain the usual DOSTM clock programs. If you are unsure how to COPY a file or how to create an AUTOEXEC.BAT file, consult your DOSTM manual.

Now, add the ASTCLOCK program to your AUTOEXEC.BAT file. ASTCLOCK is a utility program which reads and displays the current time and date from the I/O Plus II at each power up or reboot of the system. It then exits to DOSTM ("A >") when finished.

The following sequence of commands will create an AUTOEXEC.BAT file to automatically set the time and date for you every time you turn on or reboot the computer:

```
COPY CON: AUTOEXEC.BAT < enter >  
ASTCLOCK < enter >  
Function key F6 < enter >
```

Your AUTOEXEC.BAT file may contain other commands in addition to running ASTCLOCK.

5.2 Setting the TIME and DATE

You need to execute the SETCLOCK utility whenever you want to update the time or date of the I/O Plus II board's internal clock. The DOSTM TIME and DATE commands only update the system's time and date parameters; they will not update the time and date values stored in the I/O Plus II clock chip.

To set the clock on your I/O Plus II (remember, the SETCLOCK program must be on your DOSTM diskette) , type in the following instruction:

SETCLOCK < enter >

The system will display the current date and time. Typing DATE and TIME allows you to update these values in the I/O Plus II's clock chip. When you are done, press keys Ctrl and Alt simultaneously, and hold while pressing Del (reboot) to exit the SETCLOCK utility. (Note: The REBOOT is required to set the I/O Plus II clock parameters.)

If you replace the battery, be sure to use the SETCLOCK procedure to restore the proper time and date.

5.3 Device Addressing of the Clock-Calendar

This technical information is for reference only: you do not need to read this section to use the Clock-Calendar feature. The clock-calender is at I/O address hexadecimal 2C0 and uses 32 contiguous locations for programming functions. See Appendix C for a breakdown of programming functions and locations.

6.0 Game Adapter Port

In order to be able to use either an IBMTM-compatible joystick or Apple II joystick (s), three game adapter ports (joystick connectors) exist on the I/O Plus II card.

6.1 Mounting the Connectors

If you Have an IBMTM Type Joystick

Place the I/O Plus II card so that the black mounting bracket is towards the right. Near the top left corner of the card is the set of pins designated as J7 (see Diagram A).

Notice the interface cable supplied with your card. It has a small plastic connector at one end and a DB15S (socket or female type) connector at the other end. The end with the small plastic connector plugs into J7 of your I/O Plus II card.

The cable is routed through an expansion slot in the rear panel of the PCTM to connect to the IBMTM joystick cable. If you have an ConnectAllTM, you can mount the DB15S connector in the DB15 slot in the bracket where it can be connected to the joystick cable.

Position the connector over J7. Make sure that pin 1 on the cable is matched up with pin 1 on J7. (Pin 1 on J7 is designated by a "1"; the V-shaped notch on the cable's connector means that pin 1 is on that corner.) The cable should be extending to the right, over the board. Gently press the connector onto the row of pins. It should slide on easily with even pressure.

If you Have Apple II Type Joystick (s)

Locate the two sets of pins in the top left corner of the card, designated as J5 and J6. The cables for the joysticks can be plugged into both J5 (joystick A, buttons A1 and A2) and J6 (joystick B,

buttons B1 and B2). If you have only one joystick, the cable can be plugged into either J5 or J6. Pin 1 on both J5 and J6 is designated by a "1". Make sure pin 1 on the port matches up with pin 1 on the cable (designated by a dot above the pin). The cable(s) should be routed through an expansion slot in the rear panel of the PC™. With some cables, you may have difficulty passing the connector through the slot; the connector may need to be disassembled first.

When using Apple II type joystick(s), a user-supplied IC1 (74LS #5) must be plugged in on U1. U1 is located immediately below J6 (see Diagram A). IC1 must be removed when using an IBM™ type joystick.

Note: When plugging in the IC, make sure that the notch on the IC matches the position of the notch in U1. This will ensure that pin 1 is positioned correctly.

6.2 Configuration

In order to enable the game hardware, all of the required parts must be installed and a jumper should be inserted in the configuration programmer.

Place the I/O Plus II card so that the black mounting bracket is towards the right, and find the six jumper pin pairs immediately below the I/O Plus II trademark. You should place a jumper so that it bridges the bottom set of pins, designated as G.

6.3 Reconfiguring Your Software

The game port is totally software-compatible with the IBM™ game adapter when using the IBM™ type joystick.

Apple II type joysticks return slightly different values. However, since most quality software allow for centering of the sticks upon initialization, this should present little difficulty.

Note: Since there are always variations among joysticks, some software may not function properly, regardless of whether IBM™ or Apple II type joysticks are being used. Therefore, suggests that you buy only *quality* software and make sure that a joystick-centering function is provided.

6.4 Device Addressing of the Game Adapter

The game adapter is at I/O address hexadecimal 201. This technical information is for reference only; you do not need to know this to use the game adapter.

6.5 Disabling the Game Adapter Port

The game adapter port on the I/O Plus II card can be completely disabled by removing the jumper discussed in section 6.2.

7.0 Installing Your I/O Plus II Card

The I/O Plus II card can be inserted in any one of the five expansion slot receptacles on the PC™ system board.

CAUTION: BE SURE THE POWER IS OFF AND THE POWER CORD IS REMOVED FROM THE PC BEFORE INSTALLING OR REMOVING ANY EQUIPMENT.

1. Select a free expansion slot, and find the black metal bracket that covers the cut out in the back panel of the PC™ chassis. Remove and save the bracket-retaining screw using a small flathead screwdriver. Remove the bracket.
2. Line up your I/O Plus II card and position its front bottom corner in the card guide channel. Keeping the top of the I/O Plus II level, lower the I/O Plus II until its edge connector is resting on the expansion slot receptacle. Using an evenly distributed pressure, press the I/O Plus II straight down until it seats in the expansion slot. Replace the bracket-retaining screw that was removed in step 1.
3. ((Parallel printer and/or serial #2 options only) If your PC™ has a cut out above the keyboard connector on the rear panel, route the adapter cable(s) under all the cards and out to the cut out. The cut out's plastic cover can be removed easily by pressing it towards the rear.

If your PC™ does not have the cut out, you can route your cable(s) through the gap at the top of the mounting bracket. The end of the cable(s) can be attached to the optional AST "ConnectAll" mounting device for a neat, secure installation.

4. It is now time to check to see if everything works. You can replace the system unit's cover prior to check out or you can

wait until later. To replace the cover, carefully slide the cover from the front until it stops securely against the rear panel. Reinstall the two screws you removed earlier from the lower corners.

5. Replace the power cord to the system unit and be sure that the keyboard and the monitor connectors are plugged in.

7.1 Testing the New Installation

1. Insert a DOSTM diskette in drive A, and turn on the power. If everything was done correctly, the system will boot as normal.
2. Run the IBMTM diagnostic routines to check out the features you have just installed. See your *Guide to Operations* manual for instructions. Note: The diagnostic routines do not test the Clock-Calendar feature.
3. After you have finished the diagnostic routines, insert the DOSTM diskette that you have installed with the AUTOEXEC.BAT file. Reboot the system (press Ctrl and Alt simultaneously and hold while pressing Del). The ASTCLOCK program should come up and display the current time and date. In most cases the clock should give the correct time with the exception of time zone differences. Use the SETCLOCK program to set/reset the clock on your I/O Plus II.

8.0 User Upgrade Information

The I/O Plus II card is designed to allow easy user upgrade. To order the optional items, please use the following part numbers.

Serial Option

- Order part number IO-000S for async communication (RS-232) upgrade kit which consists of a UART, interface ICs, adapter cable, and documentation.

Parallel Printer Option

- Order Part number IO-000P for parallel printer upgrade kit which consists of all the necessary ICs, printer adapter cable, and documentation.

Diagnostic Programs

Order part number IO 199 for the comprehensive I/O Plus II diagnostics which test async port (COM1 and COM2), parallel printer port (LPT1 and LPT2), Clock-Calendar, and game adapter port.

Note: Although the I/O Plus II card is designed for easy user expansion, the warranty coverage applies only to the configuration of the board as originally shipped from the factory. The expansion sockets and any additional expansion-related components are not warranted.

Appendix A Recommended Serial Port Cabling

This section contains pin connections and wiring configurations for interfacing the serial port on your I/O Plus wiring other product interfaces, consult Appendix E of this manual and your serial device's manual, or call your printer manufacturer and tell them you wish to connect to an IBM PC™ Asynchronous Serial Port. Your I/O Plus II serial port is compatible with the IBM serial port.

DTE Type Cabling

The following interface diagrams refer to DTE interfaces only.

Suggested wiring to MODEM devices (Haye Stack Smart MODEM, Novation Cat, UDS, etc):

I/O Plus II Serial Port Connector	MODEM Port Connector
1	1
2	2
3	3
4	4
5	5
6	6
7	7
8	8
20	20
22	22

Use a DB25S (female/socket) connector for the I/O Plus II side and a DB25P (male/plug) connector for the MODEM side.

Suggested wiring for NEC 7700 series, II 810 series, Epson MX-100-3 and Brother HR-1 serial printers:

	I/O Plus II Serial Port Connector	Printer Port Connector
	1	1
	2	3
	3	2
	4	5
TI, Brother, Epson only	5	11
NEC printer only	5	19
	6, 8	20
	7	7
	20	6, 8

Pins 6 and 8 on the PC™ side are wired together and connected to pin 20 from the printer. The same is true in the “other direction”.

This wiring allows the printer to inform the PC™ that its receiving buffer is full. Use a DB 25S (female/socket connector for the I/O Plus II serial port and a DB25P (male/plug) for the printer. If you have a printer like the NEC 7720 (which requires a DB25S), you will need to use an adapter to hook up to the current.

Suggested wiring for the Qume Sprint 9/45, 9/55 printers:

Suggested wiring for the Qume Sprint 9/45, 9/55 printers:

I/O Plus II Serial Port Connector	Printer Port Connector
1 -----	1
2 -----	3
3 -----	2
4 -----	5
5 -----	20
6 , 8 -----	4
7 -----	7
20 -----	6 , 8

This wiring allows the Qume printer to inform the PC™ that its receiving buffer is full. Use DB25S (female/socket) for the I/O Plus II serial port and a DB25P (male/plug) for the Qume printer.

Suggested wiring for CRTs and printers running at low baud rates (110-300):

I/O Plus II Serial Port Connector	CRT/Printer Port Connector
1 -----	1
2 -----	3
3 -----	2
7 -----	7
4 , 5 -----	---
6 , 8 -----	20
-----	5 , 20 or 4, 5 if needed

This wiring does not use standard EIA RS-232C handshaking; however, it should work with most CRTs and some printers. Use DB25S (female/socket) for the I/O Plus II serial port and a DB25P male/plug) for the CRT or printer (in most cases). Notice that pins 5 and 20, or 4 and 5 on the CRT side can be wired together. Consult the user's manual for your CRT or printer for your specific configuration.

Suggested wiring for the Diablo 620 printer:

I/O Plus II Serial Port Connector	Diablo 620 Serial Port Connector
1 -----	1
2 -----	3
3 -----	2
5 -----	4
7 -----	7
6 , 8 -----	20
20 -----	6

This arrangement allows the Diablo to inform the PC™ side of the interface that its receive buffer is full. Notice that pins 6 and 8 on the PC™ side are wired together, and then commonly connected to pin 20 on the Diablo 620 side.

Suggested wiring for the Smith-Corona TP-1:

I/O Plus II Serial Port Connector	Smith-Corona Serial Port Connector
1 -----	1
2 -----	3
3 -----	2
4 -----	5
5 -----	4
6 , 8, 20	
7 -----	7
	6, 8, 20

This arrangement gives the TP-1 sufficient control over output from the PC™ side of the interface. Notice that pins 6, 8, and 20 are connected to each other on either side of the link. This allows both devices to remain in a ready state, while pins 4 and 5 actually control the flow of data from one side to the other.

Appendix A (Continued)
 DCE Type Cabling

The following interface diagrams refer to DCE interfaces only.

Suggested wiring to MODEM devices (Haye Stack Smart MODEM, Novation Cat, UDS, etc):

I/O Plus II Serial Port Connector	MODEM Port Connector
1	1
2	2
3	3
4	4
5	5
6	6
7	7
8	8
20	20
22	22

Use a DB25S (female/socket) connector for the I/O Plus II side and a DB25P (male/plug) connector for the MODEM side.

Suggested wiring for NEC 7700 series, TI 810 series, Epson MX-100-3 and Brother HR-1 serial printers for serial # 2 in DCE configuration:

	I/O Plus II Serial Port # 2 Connector	Printer Port Connector
	2	2
	3	3
TI, Brother, Epson only	4	11
NEC printer only	4	19
	5	5
	6	6
	7	7
	20	20

This wiring allows the printer to inform the PC™ that its receiving buffer is full. Use DB25S (female/socket) connector for the I/O Plus II serial port and a DB25P (male/plug) for the printer.

Suggested wiring for the Qume Sprint 9/45, 9/55 printers to the serial # 2 in DCE configuration:

	I/O Plus II Serial Port # 2 Connector	Printer Port Connector
	2	2
	3	3
	4	20
	5	5
	6	6
	7	7
	20	4

This wiring allows the Qume printer to inform the PC™ that its receiv-

ing buffer is full. Use a DB25S (female/socket) for the I/O Plus II serial port and a DB25P (male/plug) for the Qume printer.

Suggested wiring for CRTs and printers running at low baud rates (110-300) to the serial # 2 in DCE configuration:

I/O Plus II Serial Port # 2 Connector	CRT/Printer Port Connector	2 2
2 -----	2	
3 -----	3	
7 -----	7	
4, 5	-- --	
20 -----	20	
-- --	5, 20 or 4, 5 if needed	

This wiring does not use standard EIA RS-232C handshaking; however, it should work with most CRTs and some printers. Use DB25S (female/socket) for the I/O Plus II serial port and a DB25P (male/plug) for the CRT or printer (in most cases). Notice that pins 5 and 20, or 4 and 5 on the CRT side can be wired together. Consult the user's manual for your CRT or printer for your specific configuration.

Suggested wiring for the Diablo 620 printer:

I/O Plus II Serial Port Connector	Diablo 620 Serial Port Connector
1 -----	1
2 -----	3
3 -----	2
5 -----	4
7 -----	7
6 -----	20
20 -----	6

This arrangement allows the Diablo to inform the PC™ side of the interface that its receive buffer is full. Notice that pins 6 and 8 on the PC™ side are wired together, and then commonly connected to pin 20 on the Diablo 620 side.



Suggested wiring for the Smith-Cornona TP-1:

I/O Plus II Serial Port Connector	Smit-Cornona Serial Port Connector
1 -----	1
2 -----	3
3 -----	2
4 -----	5
5 -----	4
6 , 8, 20	---
7 -----	7
---	6 , 8, 20

This arrangement gives the TP-1 sufficient control over output from the PC™ side of the interface. Notice that pins 6, 8, and 20 are connected to each other on either side of the link. This allows both devices to remain in a ready state, while pins 4 and 5 actually control the flow of data from one side to the other.

Appendix B

Switching Between LPT1 and LPT2

The following program can be used in the BAT mode to direct printer output, normally designated for the device attached to port LPT1, to instead be routed to the device attached to port LPT2. (The program also directs output, normally designated for the device attached to port LPT2, to instead be routed to the device attached to port LPT1.)

This can be used when your LPT1 printer (call it printer # 1) is down for service, or when you desire, say, the type style or speed of the printer attached to LPT2 (call it printer # 2). This program allows you to quickly switch between outputs without having to alter your hardware interface or change each line in programs where LPT1 or LPT2 appear as your output port designation.

If your printers are not configured to the same parameters, as defined in the PC DOS™ MODE command, it will be necessary to add two MODE statements when switching devices.

You will note that the "swap" program below is written in BASIC. Since the printer port swap is best handled in DOS™, it is necessary to invoke BASIC within the .BAT file. No RUN command is required when the BASIC all and the program file name occur on the same line.

The following batch file and BASIC program will redirect printer output from LPT1 to LPT2 or vice versa, depending on which port is being used at the time.

LPTSWAP.BAT (or a name of your choosing) with the following:

```
MODE LPT1: [parameters for printer # 2 (if needed)]  
MODE LPT2: [parameters for printer L 1 (if needed)]  
BASIC LPTSWAP
```

LPTSWAP is a BASIC file, as below. The comments are included for clarification and should not be included in the actual program:

```
10 DEF SEG = &H40           : finds port address table
20 A = PEEK (8) : B = PEEK (9) : save LPT1 address
30 POKE 8, PEEK (10):      : LPT2 address to LPT1
   POKE 9, PEEK (11)
40 POKE 10, A: POKE 11, B   : LPT1 address to LPT2
50 SYSTEM                   : return to DOS™
```

To restore LPT1 to LPT1 AND ALSO to restore LPT2 to LPT2

Use the same program, LPTSWAP, to restore your parallel printer ports to their original arrangement. Be sure to restore the proper parameters using a new batch file and MODE statements.

LPTRSTR.BAT is as follows:

```
MODE LPT1: [parameters for printer # 1 (if needed)]
MODE LPT2: [parameters for printer # 2 (if needed)]
BASIC LPTSWAP
```

Appendix C
I/O Addressing: Clock-Calendar Chip – MM58167A

I/O Address Offset	Function
00	counter-1/10000 of seconds
01	counter-1/100 and 1/10 seconds
02	counter-seconds
03	counter-minutes
04	counter-hours
05	counter-days of the week
06	counter-day of the month
07	counter-month
08	RAM-year
09	RAM-year
0A	RAM-year
0B	RAM-not used
0C	RAM-not used
0D	RAM-not used
0E	RAM-not used
0F	RAM-not used
10	interrupt status register
11	interrupt control register
12	counter reset
13	RAM reset
14	status bit
15	GO command
16	standby interrupt
1F	test mode

Counter and RAM reset format

Data	Function
01	1/10000 of seconds
02	1/100 and 1/10 of seconds
04	seconds
08	minutes
10	hours
20	days of the week
40	day of the month
80	month

Clock-Calendar base port address: 2C0

Appendix D General Procedure For Applying Patches

A patch is a short program which alters the way the operating system usually handles a particular situation. recommends the following procedure for applying "patches":

Create a DOSTM diskette which contains the DEBUG utility and the program to be patched. (Your DOSTM manual explains the use and function of the DEBUG utility.) Place this disk in drive A and boot the computer. After the patch is applied, the new (patched) version can be copied over to your working diskettes. **DO NOT APPLY PATCHES TO YOUR MASTER DISKETTES - USE BACKUPS ONLY! TEST THE PATCHED VERSION BEFORE ACTUALLY USING IT!**

In the following procedures, the user enters all boldface text, exactly as shown; **BE SURE TO INCLUDE SPACES.** Terminate each entry line with the "enter" key. The computer responds with all other output. Refer to your DOSTM manual for more information on using the DEBUG commands.

SuperSpool Printer Status Errors

When running SuperSpool versions 1.00 and 1.01 (diskette P/N 210-1160-2, 210-1160-2.1, and 210-1160-2.2) with certain application programs, a "Printer Not Available" error sometimes occurs. The following patch to your SuperSpool program will correct this.

```
A > debug superspl. com
-e 17c
04FA: 017C  2A.b4  E4.90
- e 19e
04FA: 019E  2A.b4  E4.10
-w
```

Writing 1555 bytes

-q
A >

Patch for DOS™ 1.1 Version of DISKCOMP Utility

The DOS™ 1.1 version of the DISKCOPY utility has a bug in it which only manifests itself when the user has a large amount of memory (enough to hold an entire double sided disk) and double sided disk drives. DISKCOPY will get into an error loop and try to read past the end of the source drive. The following patch will correct the problem.

```
A > debug diskcopy.com
-e861 e8 74 00
-e8d8 3d 51 00 72 02 b0 50 a2 36 05 c3
-rcx
CX 07D8
:7e3
-w
Writing 07E3 bytes
-q

A >
```

Patch for DOS™ 1.1 Version of DISKCOMP Utility

The DOS™ 1.1 version of the DISKCOMP utility contains a bug which will prevent successful operation when the user has a large amount of memory and double sided drives. The following patch will correct this problem.

```
A > debug diskcomp.com
-e6eC 38 79 00
-e768 3d 51 00 72 02 b0 50 a2 95 04 c3
```

```

-rcx
Cx 0668
:673
-w
Writing 0673 bytes          0673          bytes
-q

A >

```

Pre-configuring DOS™ 1.1 Version for Pour Drives

The following sequence of commands will patch DOS™ Version 1.1 so that it thinks there are always four disk drives in the system, regardless of the setting of system switch #1, positions 7 and 8. This patch applies ONLY to DOS™ 1.1. Once it is made, take care to distinguish this version of DOS™ from the normal version.

Pre-configuring DOS™ 1.1 Version for Pour Drives

The following sequence of commands will patch DOS Version 1.1 so that it thinks there are always four disk drives in the system, regardless of the setting of system switch # 1, positions 7 and 8. This patch applies ONLY to DOS™ 1.1. Once it is made, take care to distinguish this version of DOS™ from the normal version.

```

A >DEBUG
-L1000 0 7 2 OR L100 0 142 2 if double sided drives
-034F
04FA: 034F D0.2B (SPACE - DEBUG GOES TO NEXT LINE)
04FA: 0350 C0.C0 25.06 03.8E 00.C0 75.80 06.0E 06.10
          06.04
04FA: 0358 01.C0 04.07 01.B8 40.04 40.00
-w100 0 7 2 OR W100 0 142 2 if double sided drives
-O

```

```

A >
Reboot computer.

```

Appendix E

Wiring Your PC™ Serial Port to Remote Serial Devices Using the Electronic Industry Association RS-232C Standard Interface

Research carefully designs its RS-232 interfaces to ensure that the PC's™ operating system software and hardware will utilize the serial port in a manner consistent with IBM's™ notions of what the serial port should "look like" to the system. In addition, designs its products so they are easy to reconfigure. For example, there is no etch cutting or soldering required to reconfigure a serial port from COM1 to COM2. To make this change you simply move two jumpers to different pairs of pins.

The EIA RS-232C standard describes the arrangement of control and data signals on both sides of a serial communications interface. As a reference point to model the standard on, the RS-232 document describes an ideal case in which a data terminal is connected to a MODEM. A MODEM is a MODulator/DEModulator used to connect a terminal to a communications device. The communications device interfaces to a transmission medium (for example, phone lines) which carry the signal to a similar device connected to a port on another DTE port or the communications element of a mainframe computer system (either of which we can call the "remote").

The EIA standard provides for various signals to be sent between a data terminal (DTE) and a data communications device (DCE), to control the exchange of data to and from the local MODEM and local terminal. These signals travel on separate wires from pins on the DTE side (terminal) to pins on the DCE side (MODEM).

For asynchronous applications such as your card serial port, we are interested in the "states" of only eight or nine (of the twenty-five possible) wires between the DTE (your PC™ port) and the DCE (a MODEM or serial printer DCE port).

Let's look at an ideal case set up first so that you will become acquainted with the signal and sequence requirements of the RS-232 standard. In our ideal case scenario, we'll imagine we are connecting the serial port on your card (DTE) to a telephone MODEM (DCE). A correctly configured DCE/DTE interface will be wired "straight across"; i.e., pin 20 on the DTE side will be wired to pin 20 on the DCE side, pin 2 to pin 2, and so forth. Let's see what sort of "handshaking" (the manner in which two devices are set to interact so as to function properly has to take place.

When the DTE serial port on your PCTM wants to transmit some data it raises the voltage, or "brings up", pin 20 which is known as DTR (data terminal ready). This voltage travels to pin 20 on the DCE side where, ideally, the DCE MODEM tells itself that a communications link is being requested by the terminal device. Assuming that an open phone line exists, the DCE brings up two lines on its side of the interface; DSR (data set ready, pin 6) and DCD (data carrier detect, pin 8). When the DTE (remember, that's your PCTM port) sees voltage at its pins 6 and 8, it is free to bring up pin 4, RTS (request to send). This tells the DCE, in effect, that "I've got data to transmit to you right now!". The DCE checks to make sure it is ready to receive data and, if so, brings up pin 5, CTS (clear to send). The DTE, seeing voltage on its pin 5, starts transmitting on the wire connected to pin 2, TD (transmit data). Any incoming traffic is received at pin 3, RD (receive data). (NOTE: some MODEMs have an automatic answer mode which uses pin 22, the Ring Indicator (RI) to alert the terminal that incoming data is due. The terminal responds with DTE.) One other thing: be sure to wire pins 1 and 7. They are ground wires and can help protect your equipment from damage.

Figure A, below, shows which signals are used between the DTE and DCE and in which "direction" they travel.

Figure A

The Ideal: Terminal to MODEM

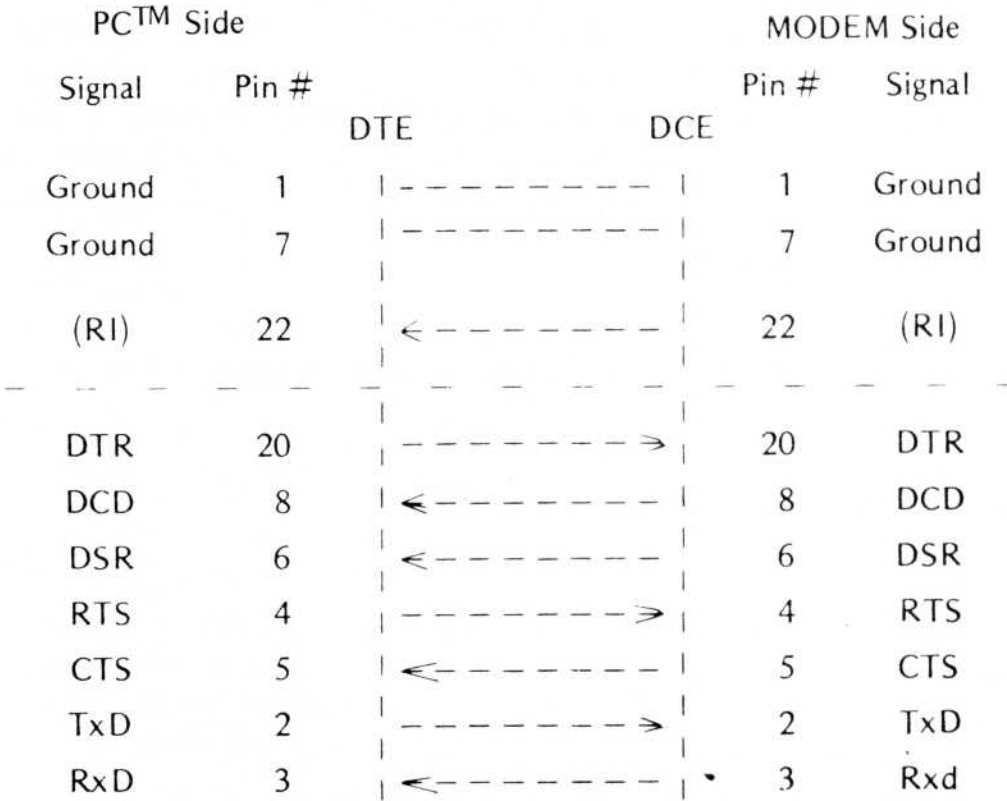

Notice that the INPUT signals on the DTE side of the interface are DCD, DSR, CTS, and RxD. Also, the DTE has OUTPUT DTR, and RTS. These are the signals which must be handled by the interface before the DTE can transmit or receive data.

Now notice the SEQUENCE in which these signals occur (top to bottom in Figure A). From the DTE's standpoint, he must send DTR, see DCD, see DSR, send RTS, and see CTS before he can transmit or receive data. That is, the INPUTS must have voltage applied to them or the interface cannot become operational. (The outputs matter only in that they are inputs to the DCE side of the interface.) The hardware which controls the DTE serial interface will

not release data to the communications link until the proper *set* and *sequence* of signals has been *received*.

One other concept: you can think of certain pins on one side of the interface as being “functional pairs”. When the serial port sends DTR, it expects to see DSR (and DCD) raised in response. DTR and DSR are signal and response to one another. For this reason we will think of them as a pair. The same is taken up again later in our discussion.

NOW LET'S LOOK AT A TYPICAL (NON-IDEAL) CASE

DTE to DTE Interfaces

As is often the case, many devices, such as serial printers, are set up as DTEs. To output data from your PC™ serial port (also DTE) to a serial printer or other DTE device requires the wiring of a DTE to *DTE* interface. Such an interface must fool each side of the link into thinking that it is receiving “response” inputs from a DCE. As mentioned above, not only must the input voltages be present, but they must become present in the correct sequence (although, this varies from device to device).

To illustrate, let's look at the case presented in Figure B.

Figure B

Example of a Specific DTE to DTE Interface

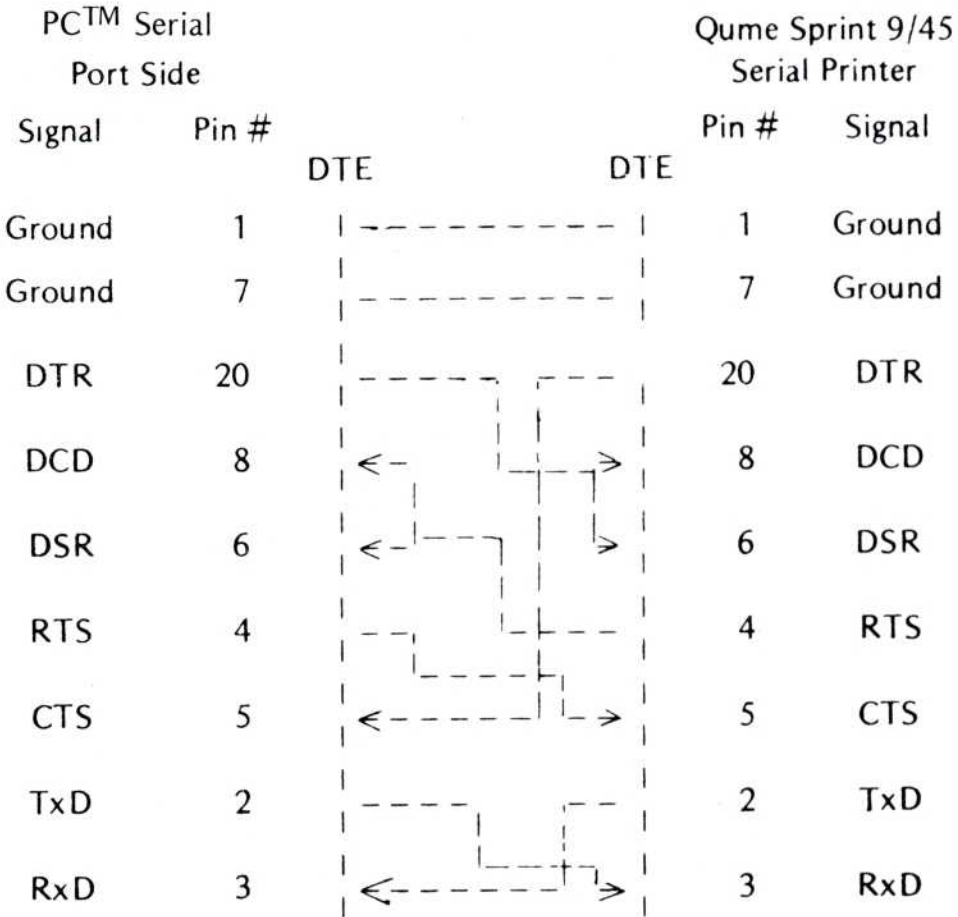

Notice that the necessary input signals have been supplied to both sides. DCD, DSR, and CTS have voltage applied to them on either side. The integrated circuit which controls the PC™ side (IRS 82-50) is fairly flexible in reading the sequence of inputs. That is why we can “drive” CTS with DTR from the printer’s side. You’ll notice that this is the only sequencing rule that we’ve broken. Why have we done this? The Qume manual explains that when the printer’s receive buffer is about to fill up it “drops” its DTR signal. Since we don’t want to lose data by overflowing the printer’s receive buffer, we need

to immediately halt the output of data from the PC™ side of the interface. The best way to do this is to immediately drop the clear to send (CTS) input on the PC™ side. By having the printer's DTR output drive the PC's™ CTS input, we can ensure that this kind of control will occur. The remainder of the interface will "idle" until the printer "raises" DTR again. (Remember, this is a specific case for Qume serial printers.)

Let's look at another example of interfacing a serial DTE printer to the PC's card serial port.

Figure C

Serial Port DTE to NEC 7700 Series Serial DTE Printer

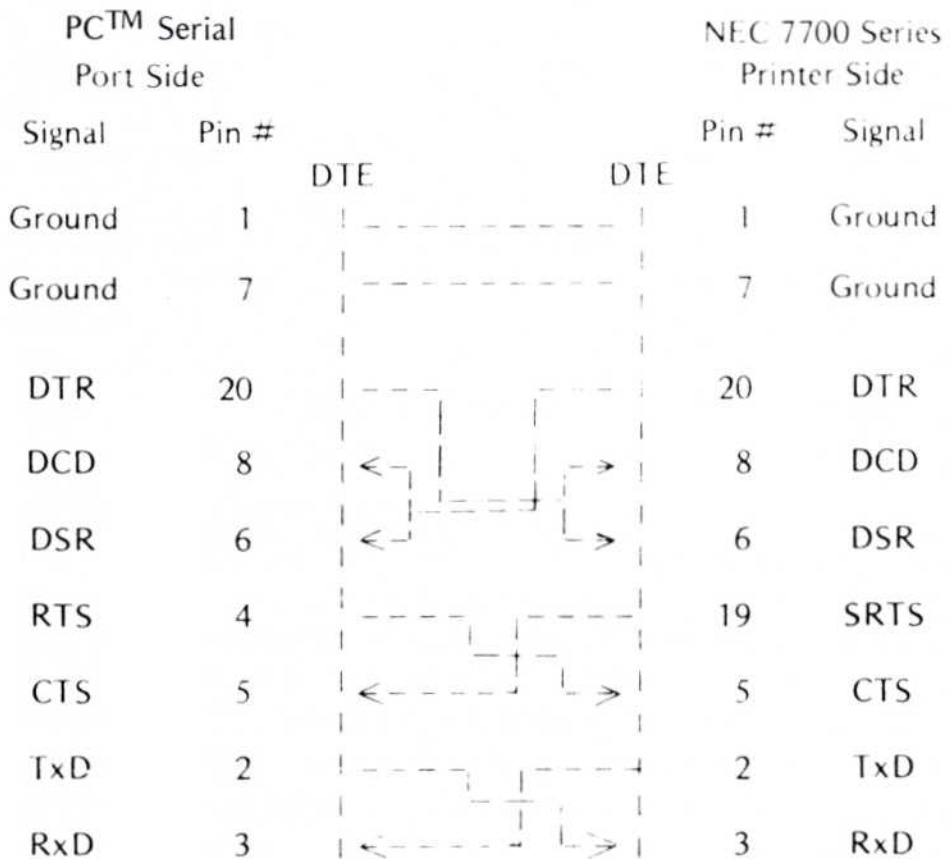

In this case, the printer uses line 19, a Secondary Request to Send (SRTS), instead of pin 4. Other than this oddity, careful examination of the interface will show that all of our DTE input and sequence rules have been followed. On both sides DCD, DSR, and CTS are raised, and in the top-down sequence we are generally trying to follow for these signals.

Another nice thing about this particular wiring is that all of the pins are driven by their functional counterparts on the other side of the interface. You'll recall in our Ideal Case scenario we mentioned functionally related "pairs" of pins. (DTR/DSR, DTS/CTS, and TxD/RxD.) Figure C shows that an element of a pair on one side of the interface, is driving its partner element on the other side of the interface. When sequence is important, this is a good way to tell if your interface. When sequence is important, this is a good way to tell if your interface will work or not.

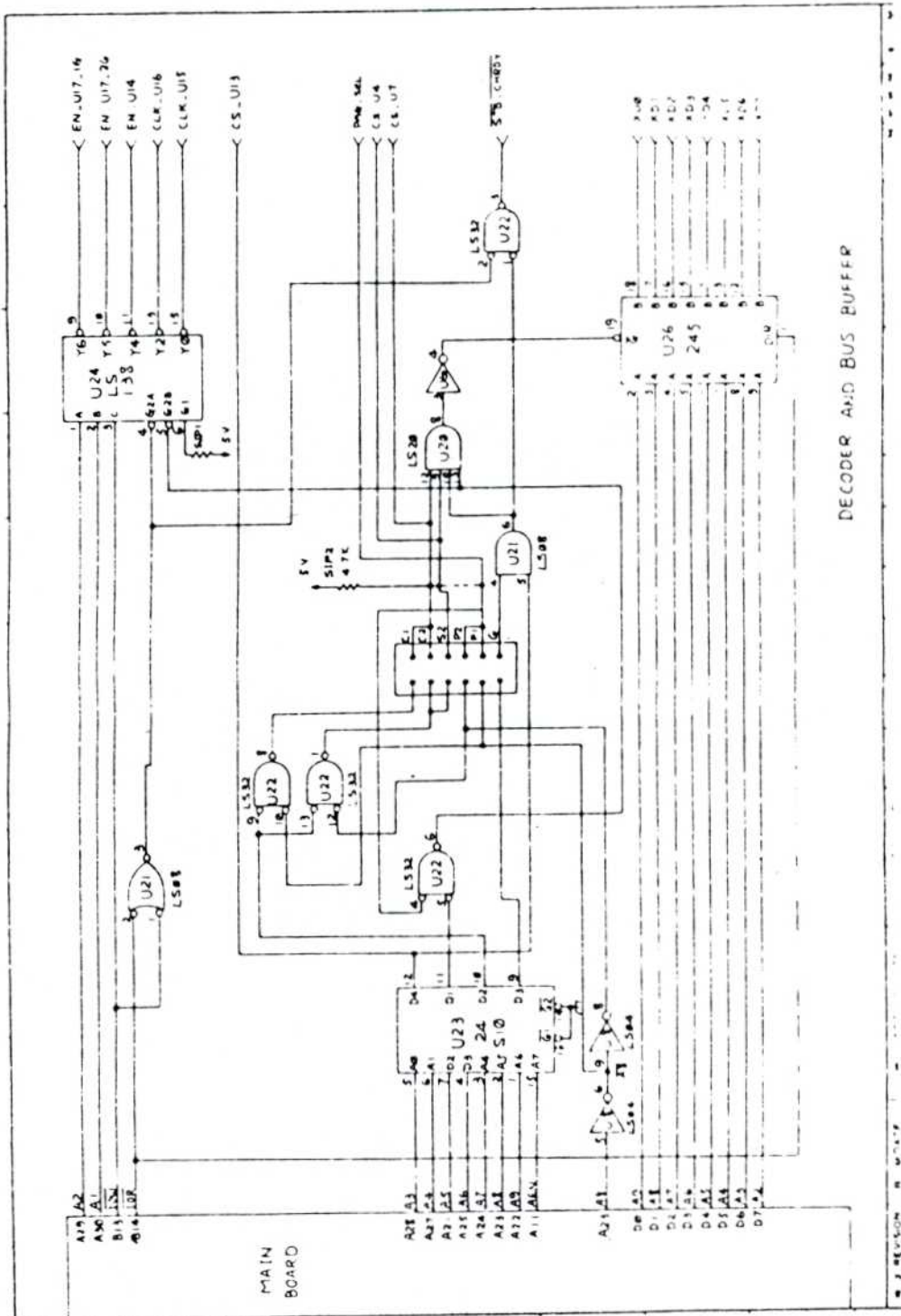

DECODER AND BUS BUFFER

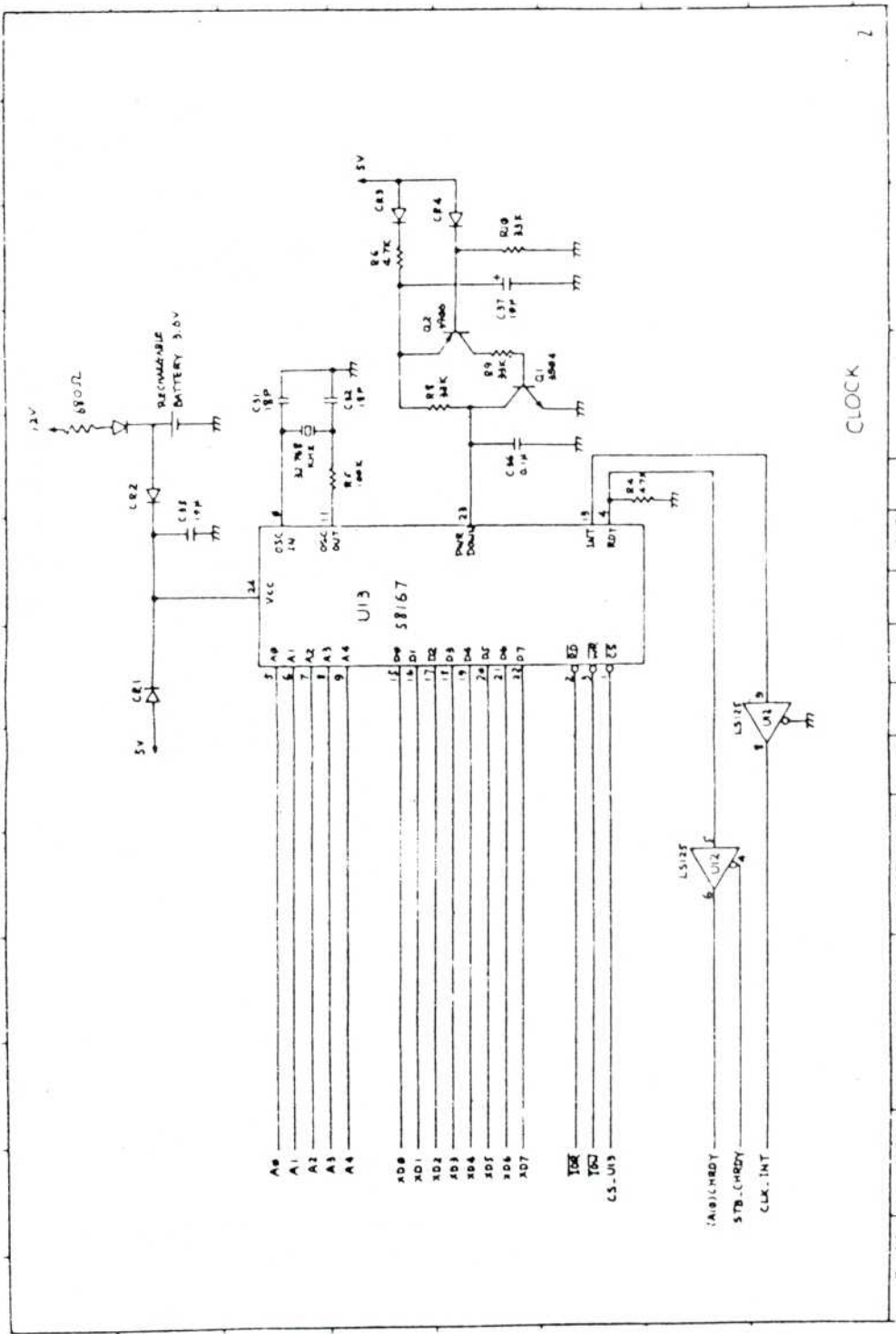

CLOCK

CU U17 26
 EN U14

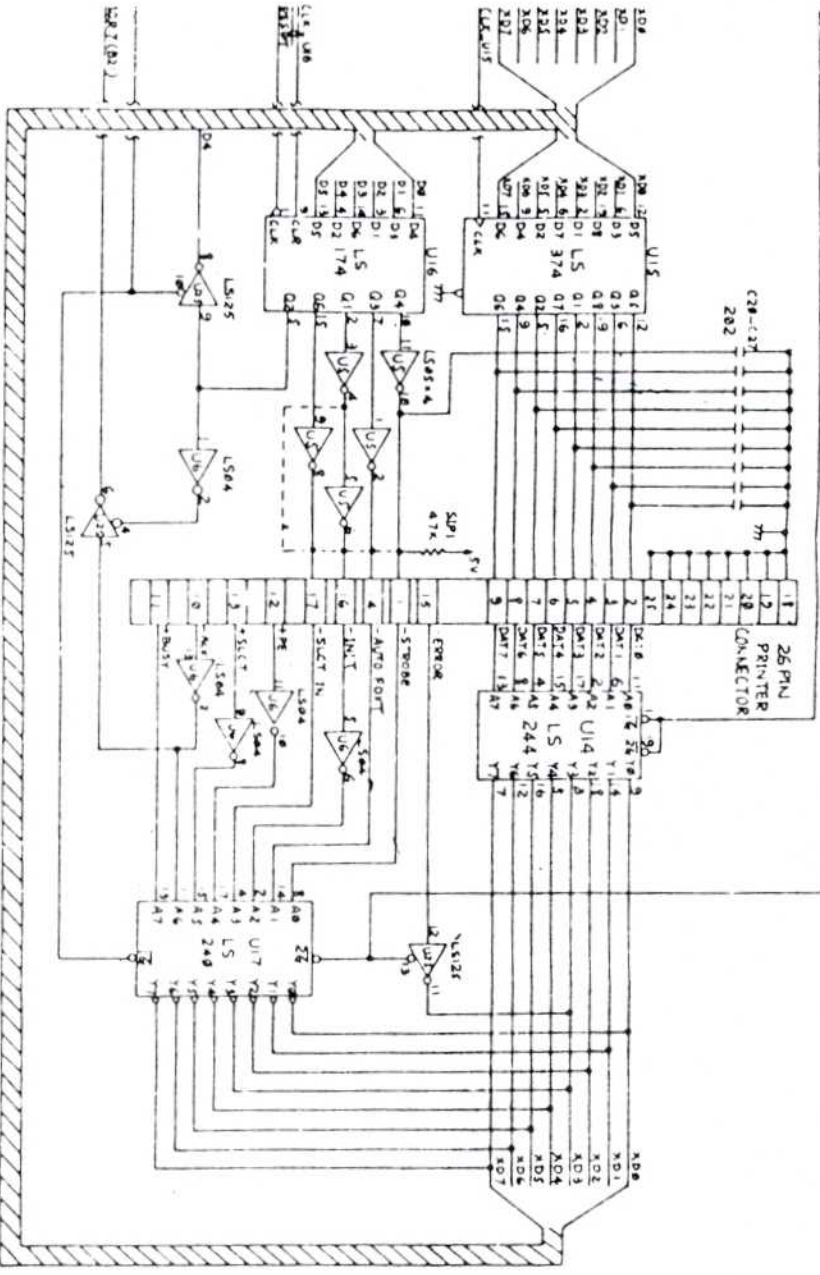

PRINTA

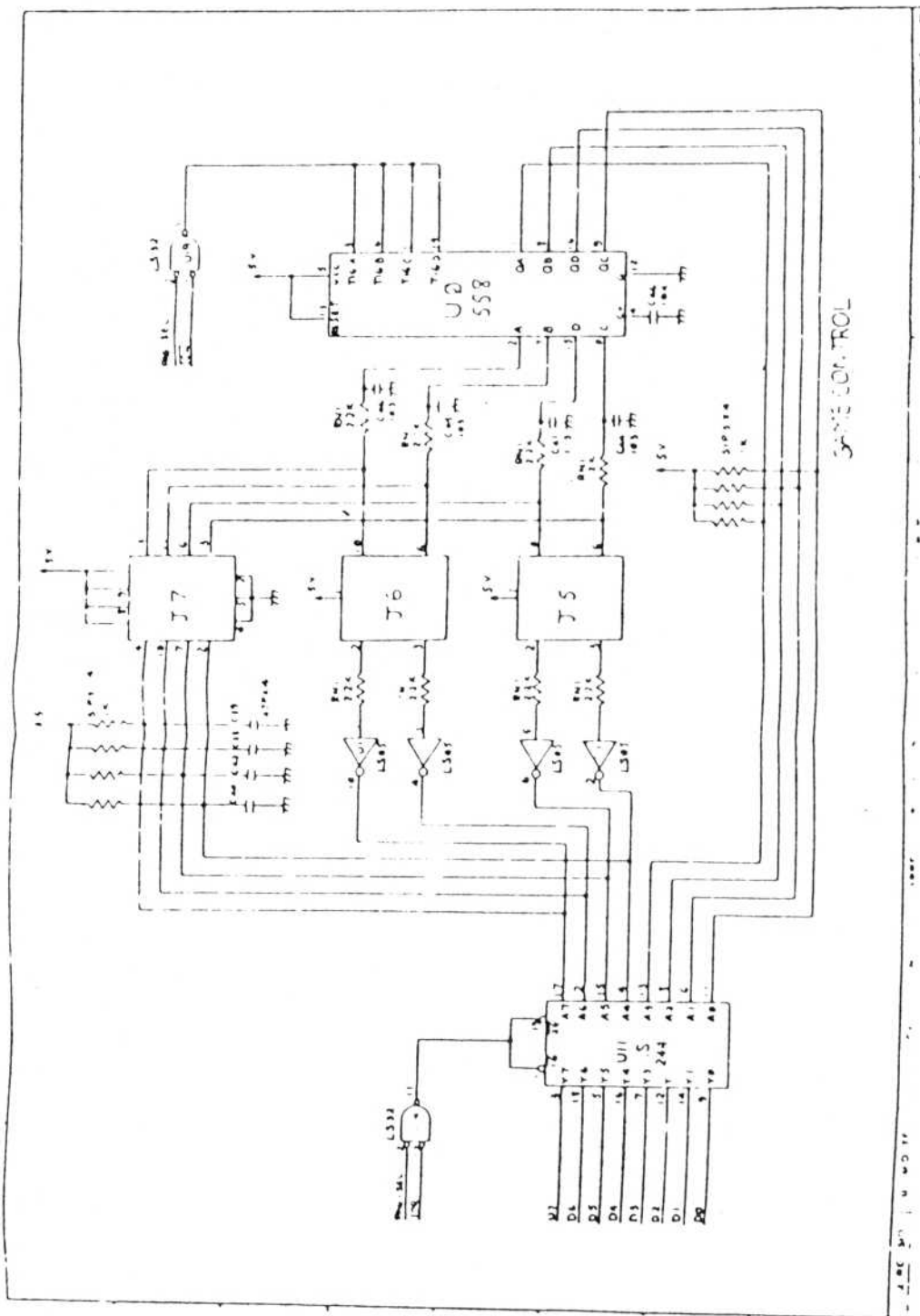

GAME CONTROL

